



SP2000-H320/S

Gas Sample Probe Series SP®

Version SP2000-H320/S heated to 320°C
with separator vessel

2.6 03.97/06.06

Special Features

Special probe behind DENOX (SCR)
Heated to 320 °C
No salt formation in the heated filter part
Condensate vessel in the gas outlet with glass globe filling for extension of the reaction surface
Optional heated condensate vessel
Integrated peristaltic pump
Connection for test gas feeding
Easy maintenance and operation

M&C Application

M&C has developed a special sampling technique for continuous gas sampling of waste gas in DENOX plants (SCR) where NH_3 is added to the flue gas in order to reduce the NO_x content. This new sampling technique has also proved to be suitable for processes with very high pollutant concentrations.

In these applications, a big problem is the measurement of NO_x , SO_2 and O_2 -concentrations. With temperatures of < 300 °C, ammonium salts are produced due to the chemical reaction of NH_3 and SO_2/SO_3 in the flue gas.

This salification blocks up filters and sample lines in a short time.

The special M&C gas sample probe SP2000-H320/S represents a good solution for these problems. In order to prevent a blocking due to salification, the probe temperature is adjusted above 300 °C.

M&C Description

The M&C gas sample probe SP2000-H320/S is based on the standard sample probe.

The gas sample probe SP2000-H320/S is temperature controlled via an integrated capillary sensor thermostat adjustable from 50 to 320 °C and including over temperature limiter and low temperature alarm.

As an option, the gas sample probe is available with a FeCu-Ni thermoelement instead of the thermostat controller. For this version, an external temperature controller is necessary.

Due to the modular design the M&C gas sample probe SP2000-H320/S can be equipped with the wide range of different sample tubes and pre-filters respectively options.

At the sample gas outlet of the probe, the gas passes a heated adapter to a non-heated condensate vessel of glass. It is filled with glass balls to extend the surface for the salification. The salt deposits and can be washed out with the condensate.

A peristaltic pump SR25.1G removes the condensate with the solved ammonium salts.

The temperature of the vessel is higher than the ambient temperature because of the hot gas stream and the heated adapter. Therefore a loss of measured components is negligible because of warm condensate. In case of DENOX application with a small content of NH_3 (normally only a few ppm) it is possible to analyse SO_2 and NO_x without great losses (only some ppm which normally can be neglected). To determine the loss, it is possible to give test gas via the probe to the analyser(s). A measuring fault can be found and calibrated.

As an option the vessel can be heated as well to suppress chemical reactions of the measured component below a defined temperature.

To the sample outlet of the vessel a heated sample line 3/4-M for max. 200 °C operating temperature can be connected.

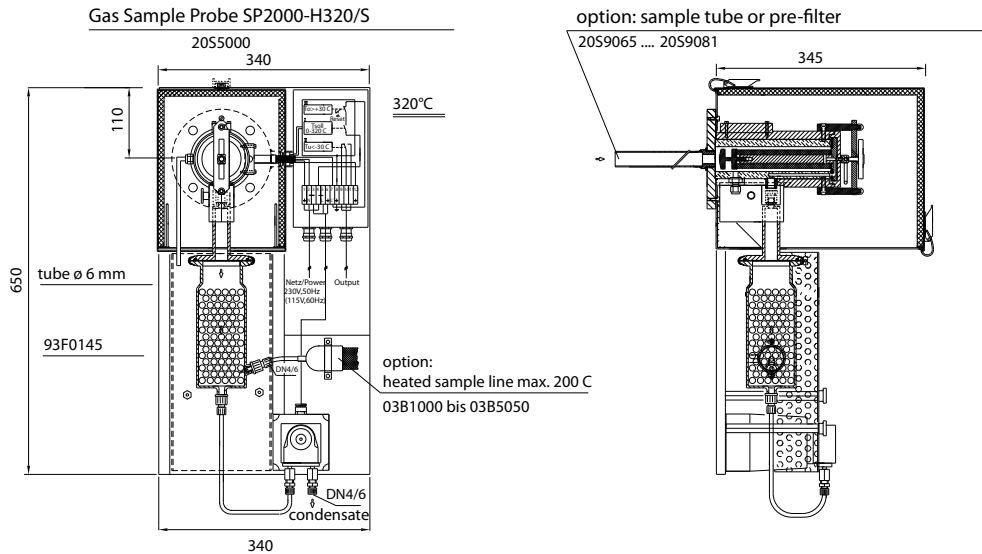

Dimensions in mm

	SP2000-H320/S	
Part No.	20S5000 (a)	20S5000 (a) + 20S9027
Temperature regulation	Thermostat adjustable 50-320 °C, with over temperature limiter and low temperature alarm as contact output alarm point $\Delta T 30$ °C, contact rating 250V 3A~ 0,25A =	with FeCu-Ni thermoelement, (instead of thermostat) option: external electronic temperature controller necessary e.g. Part No. 01B8350
Probe heating	max. 320 °C	
Ambient temperature	+5 °C to +60 °C** optionally with polyester protective housing -20 °C to +60 °C	
Volume of filter chamber	120 ml	
Sample pressure	0.4 to 2 bar abs.	
Filter element	ceramic, type S-2K 150*, filter porosity 2 μ m	
Condensate vessel	glass (optional SS 316Ti, Hastelloy®), volume 0.4l (0,15l glass ball filling)	
Adapter flange for condensate vessel	Hastelloy®	
Peristaltic pump	SR25.1G, 230/115V 50/60Hz	
Ready for operation	after 2h	
Connections sample gas outlet / condensate outlet	hose fitting DN4/6	
Connection test gas inlet	tube connection \varnothing 6 mm with blind plug, option: \varnothing 1/4" (a)	
Power supply	230V 50Hz, 800W, option: 115V 60Hz (a)	
Electrical connection	terminals max 2.5mm ² , 2x PG11 cable glands	
Electrical equipment standard	EN 61010, EN 60519-1	
Degree of protection	IP54, EN 60529	
Mounting flange	DN65 PN6, B, stainless steel 316 / 316Ti, option: 3"ANSI 150lbs RF (a)	
Connection sample tube	G3/4"i	
Material of sample contacting parts	stainless steel 316Ti, graphite, ceramic, Hastelloy, glass, FPM, PTFE, PVDF	
Weight	17 kg	

- Part-No.: 20 S 9053 2-way ball valve for shut off to process side /VA320
- Part-No.: 20 S 9330 3-way ball valve for shut off to process side /3VA320
- Part-No.: 20 S 9044 test gas inlet via check valve 0.7 bar /R
- Part-No.: 20 S 9065 and following sample tubes or pre-filters
- Part-No.: 01 B 8350 electronic temperature controller in wall mounting housing
- Part-No.: on request heating of the condensate vessel to max. 180 °C
- Part-No.: 20 S 9410 protection case of polyester

* Standard

** In case of higher ambient temperatures use option PT100 (Part No. 20S9025) or thermocouple Fe-CuNi respectively Ni-CrNi (Part No. 20S9027 resp. 20S9028) instead of the thermostate controller. Then, an additional electronic temperature controller (see data sheet 2-5.1) is necessary.

Part-No.(a) = Execution power 115V 60Hz, flange 3"150 lbs, test gas connection \varnothing 1/4".
For further technical data please see data sheet SP2000.